

Garderobe / **ungezwungen**

Montageanleitung

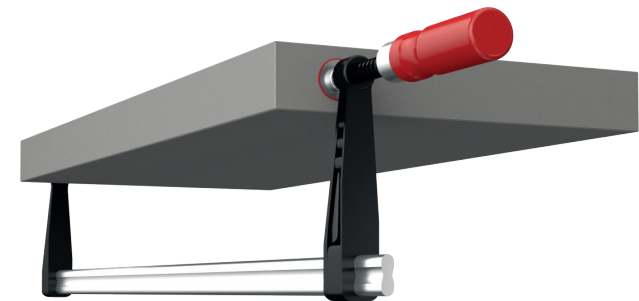

Inhalt

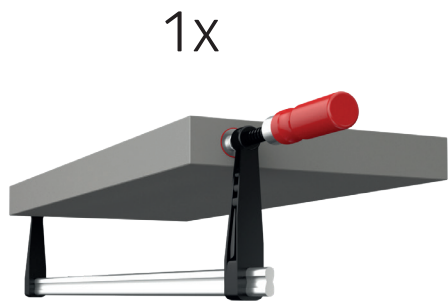
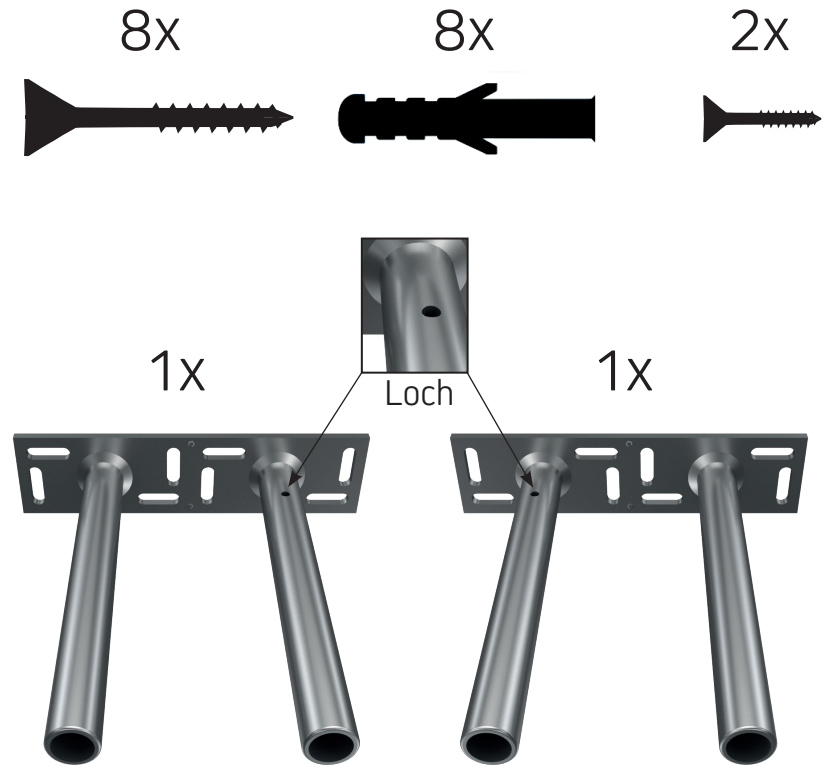

Anleitung

1 2x Halterungen an die Wand schrauben

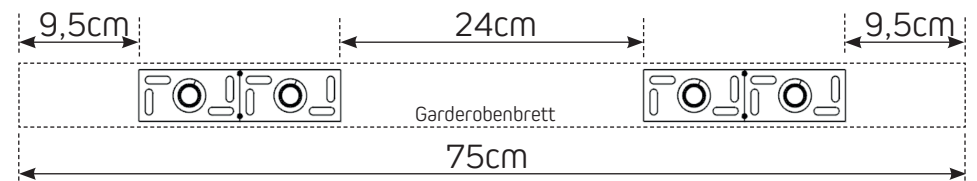
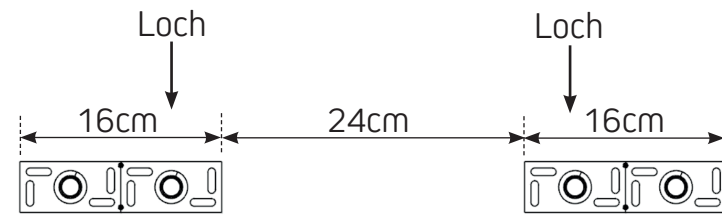
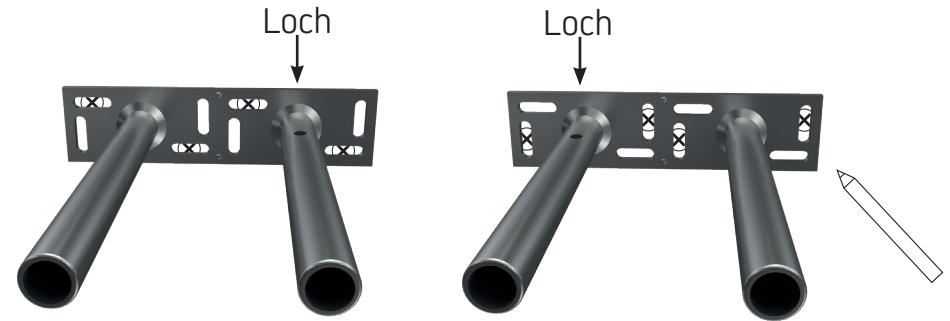
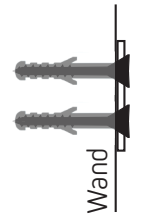

- 2 Garderobenbrett mit Zwingen auf die Halterungen schieben

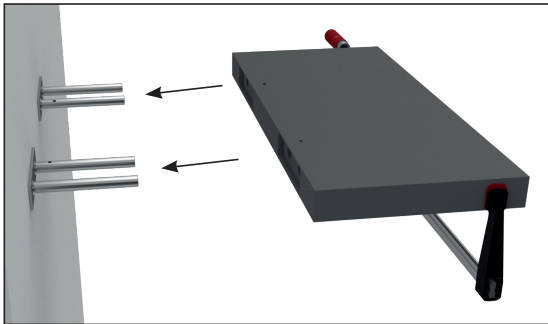

- 3

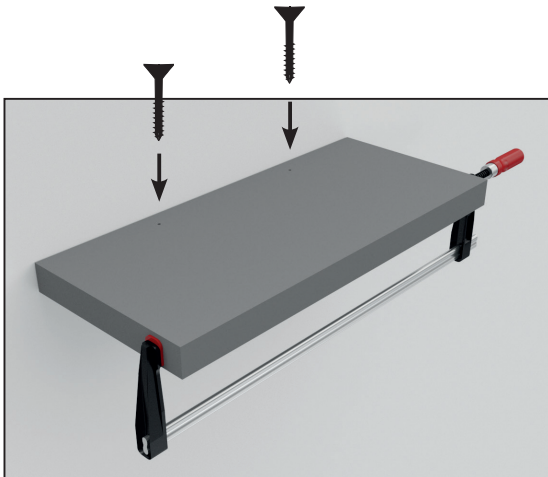

Belastung
max. 15 Kg

